

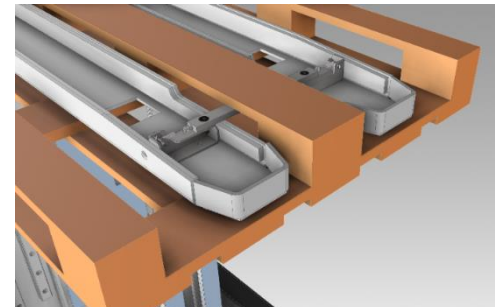

## TECHINCAL DATA:

Capacity.	1500kg
Forks opening min/max.	550-2000mm
Fork length.	1200mm
Forks External	560mm
Single fork width	180mm
Battery	24v - 210Ah
Performance hour	Approx 20 pallets in one
Min. required height.	2450mm

### Pallet-Fix



Option for "wide base", inside fork distance 1300mm.  
 Forks movement synchronized.  
 Battery charger incorporated automatic.  
 Traction electric  
 Electric controller for a delicate approach to material.  
 Operating: Opening/Closing forks oleo dynamic. Overturning of 90degree angle oleo dynamic.  
 Rotation of an angle of 180degree manual.

Samzon MPT2000-15 Pallet Inverter is equipped with the latest electronic and mechanical components. The traction group has a 2000w electrical engine. The oleo-dynamic group has a 3000w engine with an incorporated pump to obtain elevate operative times. Besides the forks are controlled by an electro-valve allowing the operator to handle their movements through simple switches over the control board. The gripper unit is made of a solid loom over there are rested on aluminum controls of polyzene runners with a high resistance and long duration. Beside the gripper is also equipped with a support surface for the paper, aligned and precise. The paper or any kind of palletizable material can also be lifted and turned over without pressure between the forks, leaving it up to the operator the choice regarding how to work.

- \*Servo-steering - Easy movement of steering wheel.
- \*Hydraulic locking-pawl for very easy handling of rotation.

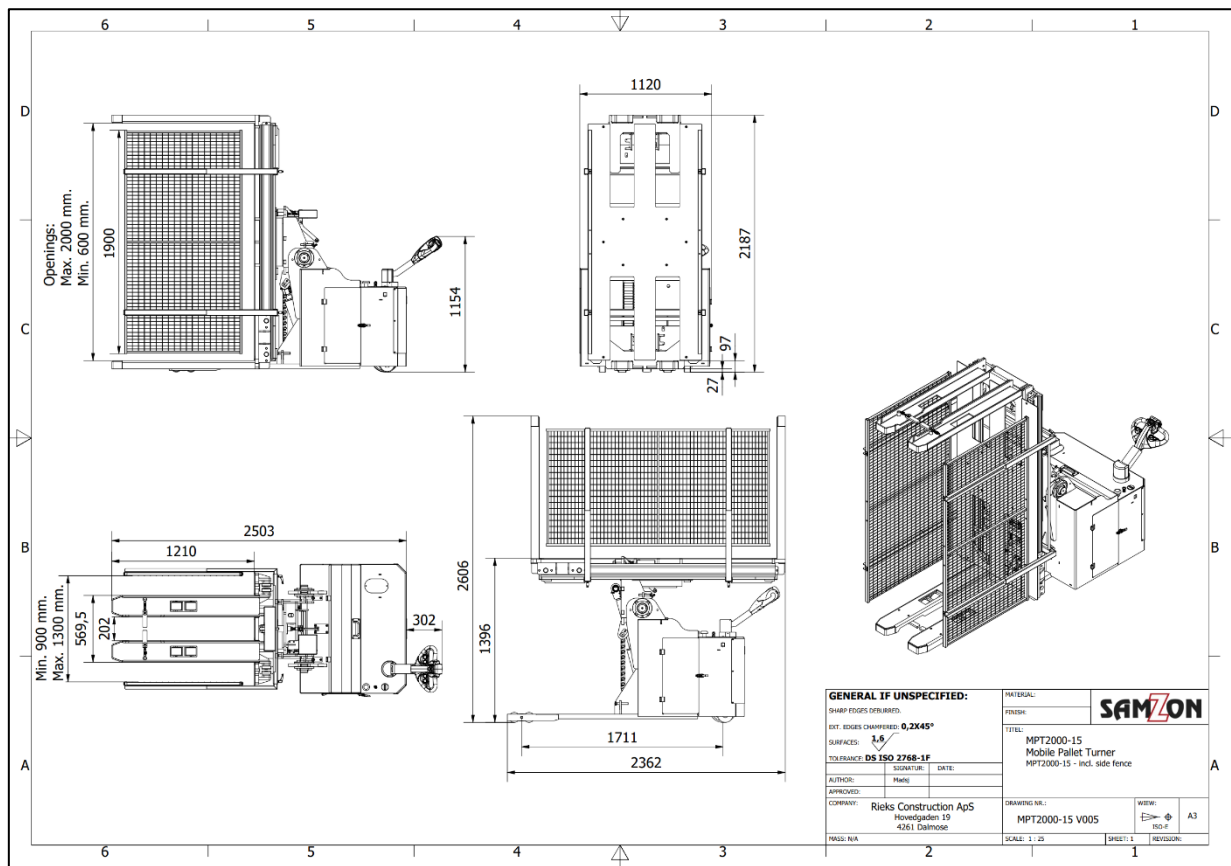
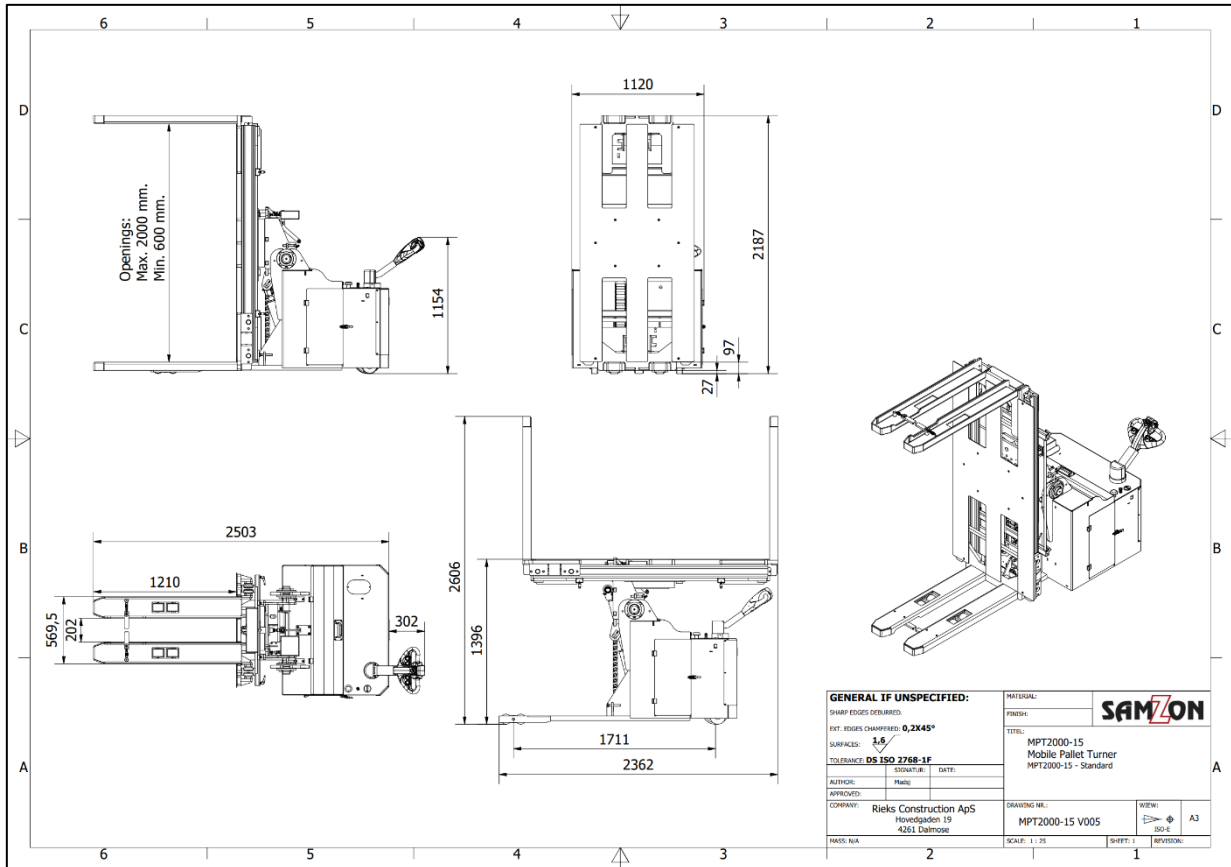

Widebase version.

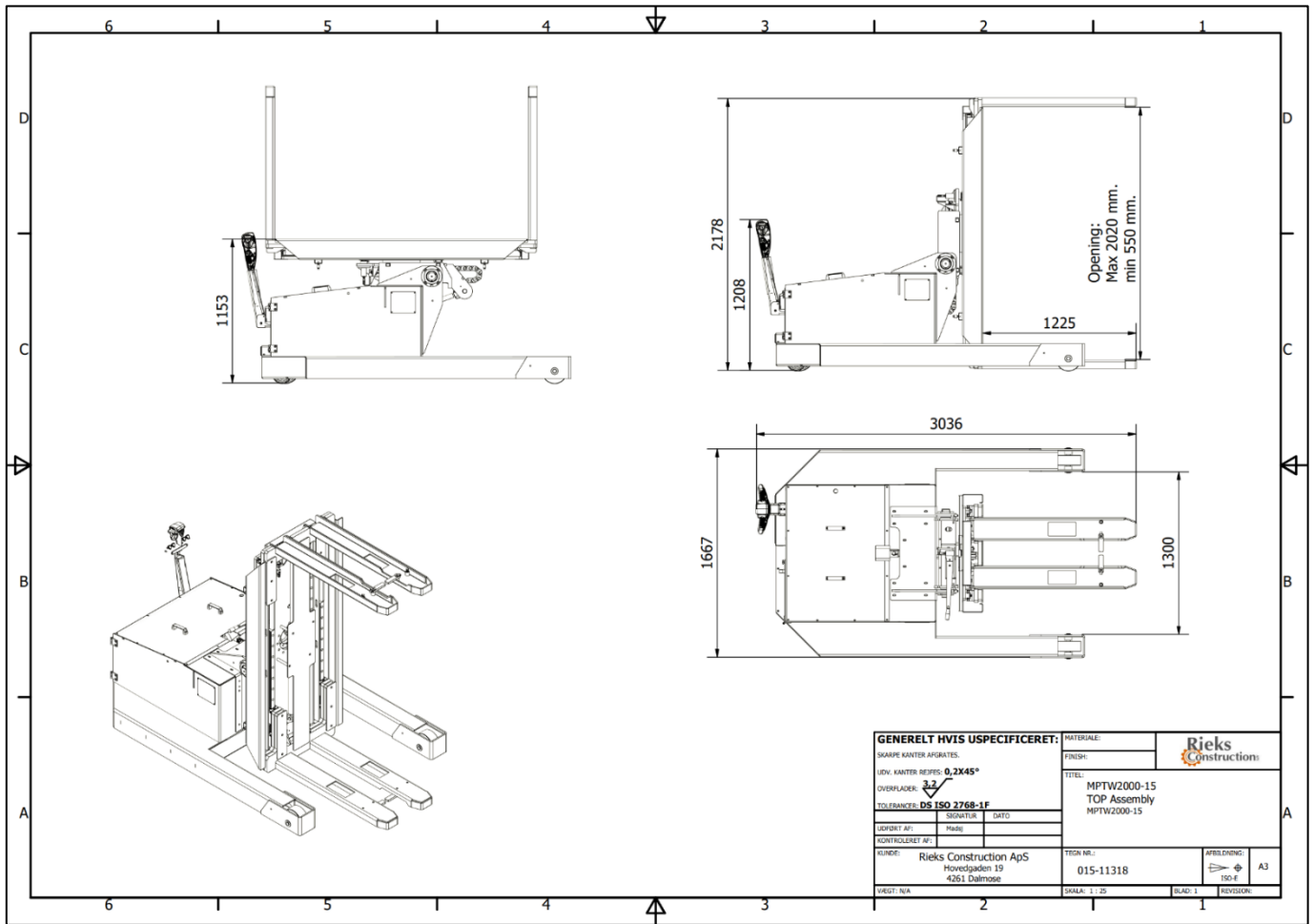

## Options.

**Second Battery Package.**

Including 24V - 210Ah Lead Acid + battery charger.

This option is also including trolley for easy change of battery, and this is easy rolled from the machine to the trolley, due to the rollers in the machine.

**Adjustable pressure-switch.**

Adjustment of clamp pressure.

Manuel adjusted by hand and possible to see the indicator on the switch.

**WIDEBASE Version.**

Frame-profiles 1300mm inside measure.

Used to manage up to 1200mm pallets in the width.

Forks run outside the pallet.

**Safety fence on both sides.**

Safety fence is adjustable, from 900mm to 1300mm inside measurement.

Powder coated as standard.

**Pallet Fix**

Used to hold the pallet on forks.

**Sparepart Kit.**

Recommended.