

MODEL. MPT1700-10

V01



TECHINCAL DATA:

Capacity.	1000kg
Forks opening min/max.	530-1700mm
Fork length.	1200mm
Forks External	520mm
Single fork width	180mm
Battery	24v - 210Ah
Turning radius.	1680mm
Forks movement synchronized.	
Battery charger incorporated automatic.	
Traction electric-mechanical	
Electric controller for a delicate approach to material.	
Operating: Opening/Closing forks oleo dynamic. Overturning of 90degree angle oleo dynamic.	
Rotation of an angle of 180degree manual.	

The MPT1700-10 Pallet Inverter is equipped with latest-generation mechanical and electronic components. The traction unit is equipped with an electric engine of 2kw, the oleo-dynamic set is controlled by an engine of 3kw with an incorporated pump.

The gripper unit is made of a solid loom over there are rested on aluminium controls of polyzene runners with a high resistance a long duration. Beside the gripper is also equipped with a support surface for the paper, aligned and precise.

The paper or any kind of palletizable material can also be lifted and turned over without pressure between the forks, leaving it up to the operator the choice regarding how to work.

***Servo-steering - Easy movement of steering wheel.**

***Hydraulic locking-pawl for very easy handling of rotation.**

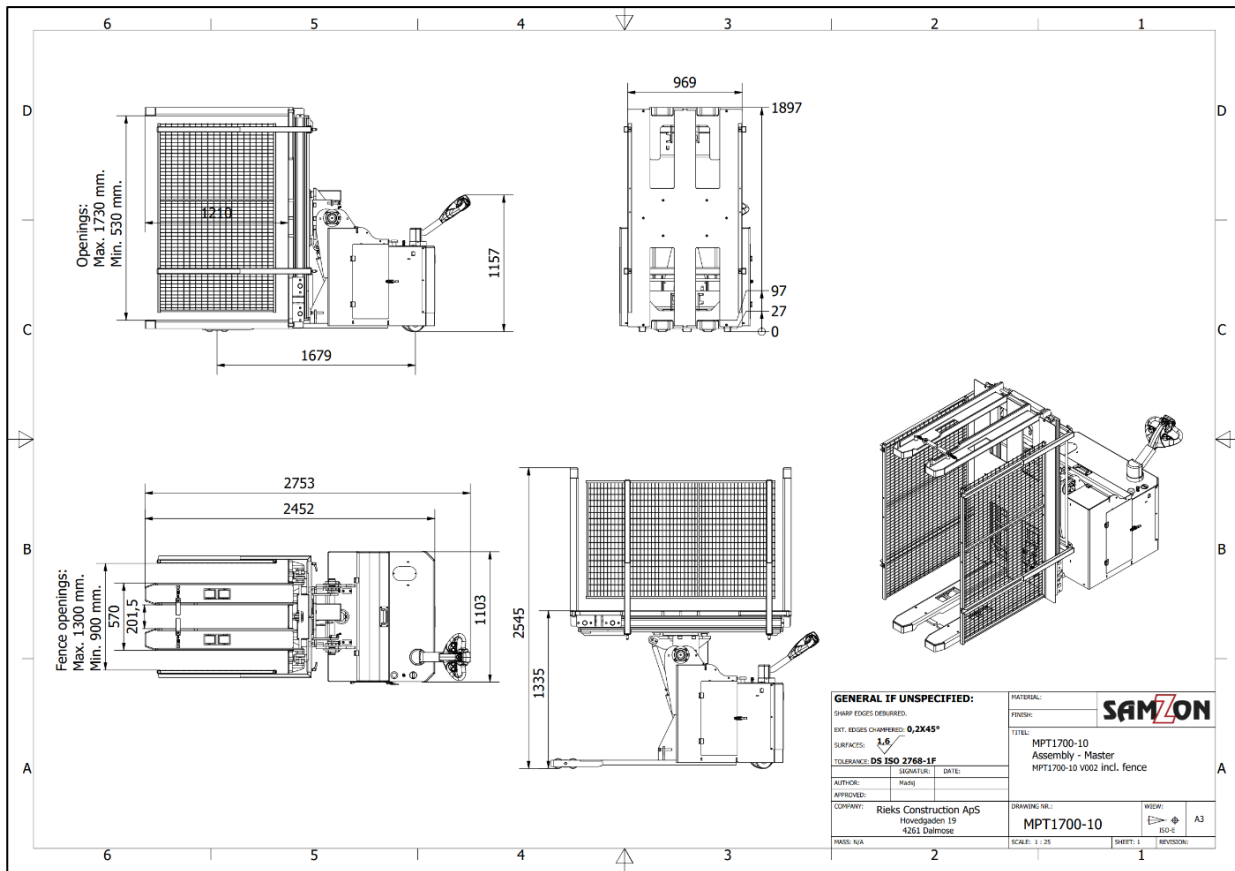
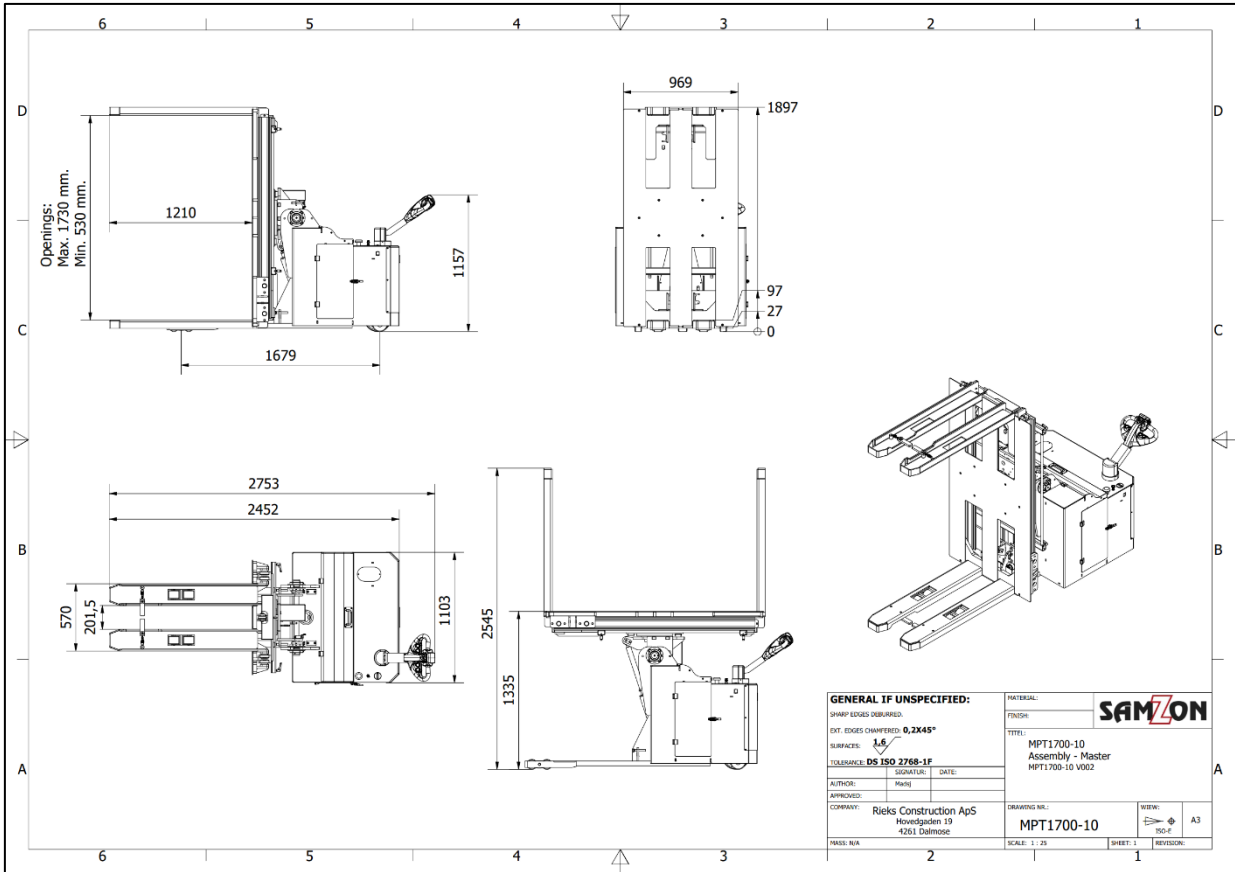

Samzon MPT1700-15 Pallet Turner
Widebase version.

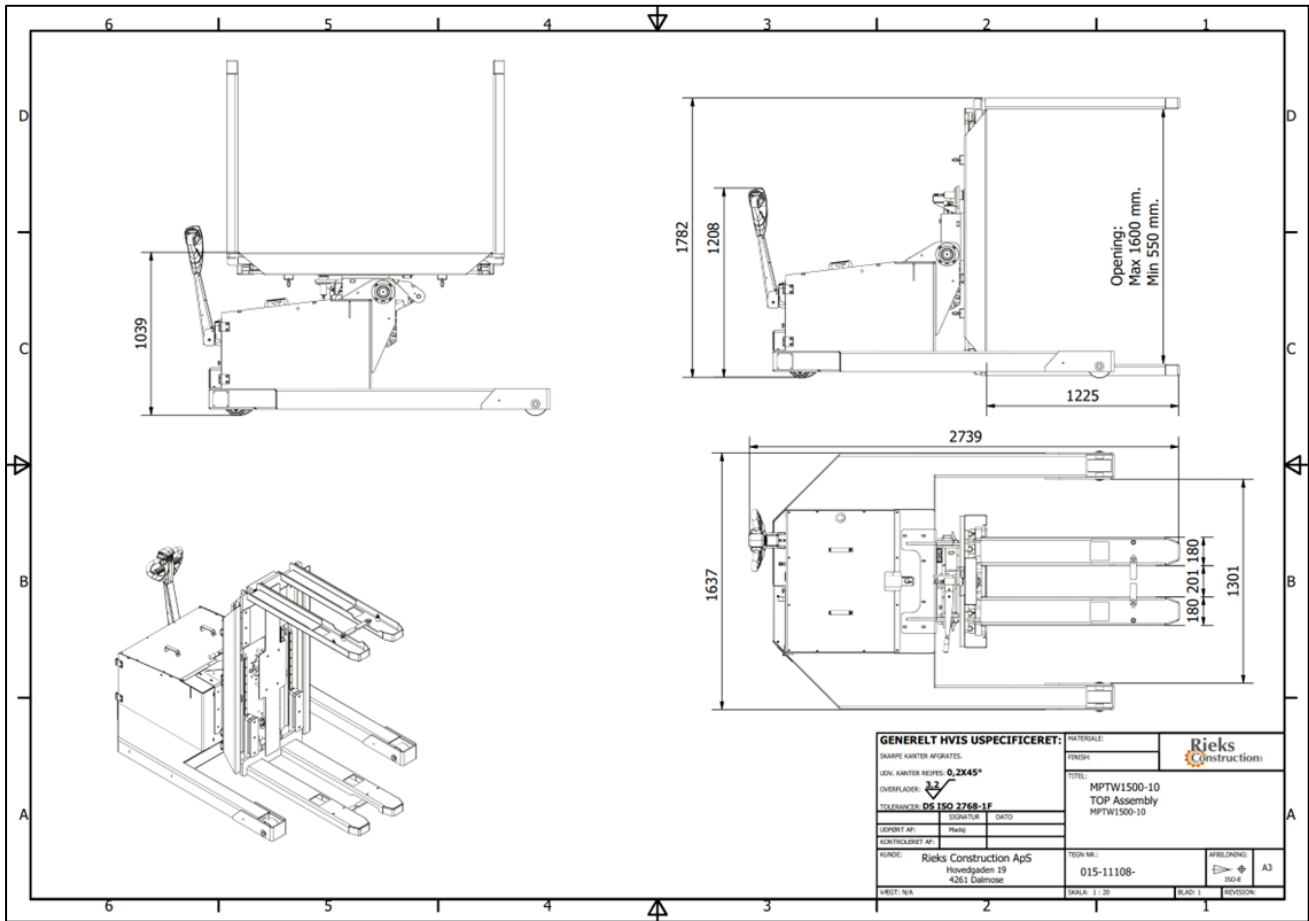

Options.

Second Battery Package.

Including 24V - 210Ah Lead Acid + battery charger.

This option is also including trolley for easy change of battery, and this is easy rolled from the machine to the trolley, due to the rollers in the machine.

Adjustable pressure-switch.

Adjustment of clamp pressure.

Manuel adjusted by hand and possible to see the indicator on the switch.

WIDEBASE Version.

Frame-profiles 1300mm inside measure.

Used to manage up to 1200mm pallets in the width.

Forks run outside the pallet.

Safety fence on both sides.

Safety fence is adjustable, from 900mm to 1300mm inside measurement.

Powder coated as standard.

Pallet Fix

Used to hold the pallet on forks.

Sparepart Kit.

Recommended.